



Your
**CUSTOM
ROTATIONAL
MOULDING**





ABOUT US

ROTO is a global producer of high-quality rotomoulded products from polyethylene, polypropylene, polyamide, XPE and ABS with production factories in four European countries.

ROTO is a family business company that is presented on the market as a successful manufacturer and reliable business partner for more than 45 years.

ROTO is a leading rotational moulder in Europe with over 4000 different products in range and size up to 70.000 l. These products are exported in more than 50 countries all over the world.

ROTO performs all stages of the business process, from product development, product analysing, in house tool production, prototype manufacturing, serial production, marketing & sales, distribution and after – sale service. High quality technical products are made of latest production technologies and strong R&D department.

COMPANY MISSION

The company's mission is to provide and offer high-quality, multifunctional, environmentally safe products that are distinguished by modern design and greater added value. Partners achieve satisfaction with quality products and services, in short delivery times and competitive prices.

Roto certified and patented many innovative products. We have received numerous national and international awards, including:

- award for outstanding business achievements, 1996,
- a sign of quality in construction, 2009 and 2010,
- regional recognition for the rapid development of the company, 2012.

ROTO HAS THE FOLLOWING CERTIFICATIONS:

Certification of Quality ISO 9001:2015
Environmental Certificate ISO 14001:2015



OUR FACTORIES

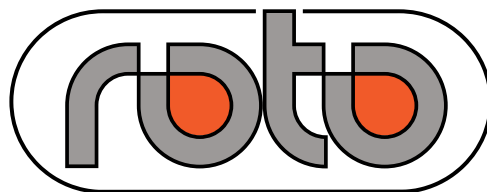

YOUR CUSTOM ROTATIONAL MOULDING



We offer you a complete
IN HOUSE SOLUTION,
from idea to serial
production!

“Roto – professionals for innovative technical solutions made of polymer to suit your needs!”

DEVELOPMENT PROCESS – from as little as 8 weeks!

01

Your
IDEA

02

3D model
design

03

Mould
manufacturing
process

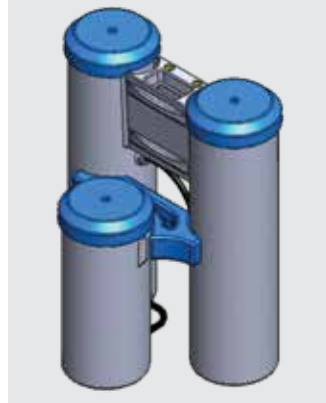
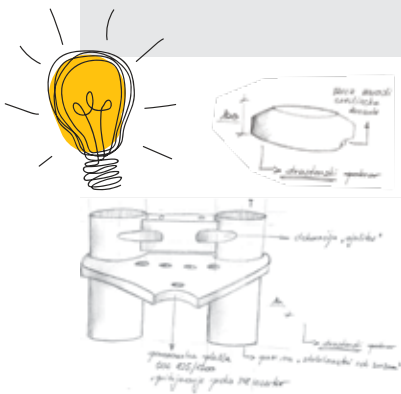

WHAT IS IMPORTANT

From your idea, with a sketch, the production of a 3D model, a prototype of the product (if needed) and tool manufacturing to a sample piece and then the serial production in just 8 weeks. Our advantage: the whole development process takes place in one location, the headquarters of our company.

Your CUSTOM moulding is Roto's key competence. Throughout the development process, we work closely together with our customers, giving them support with the design, technical solutions, and cost reduction, in this way we strive for our customers' goal: to have a product that is useful, technically perfect and fairly priced.

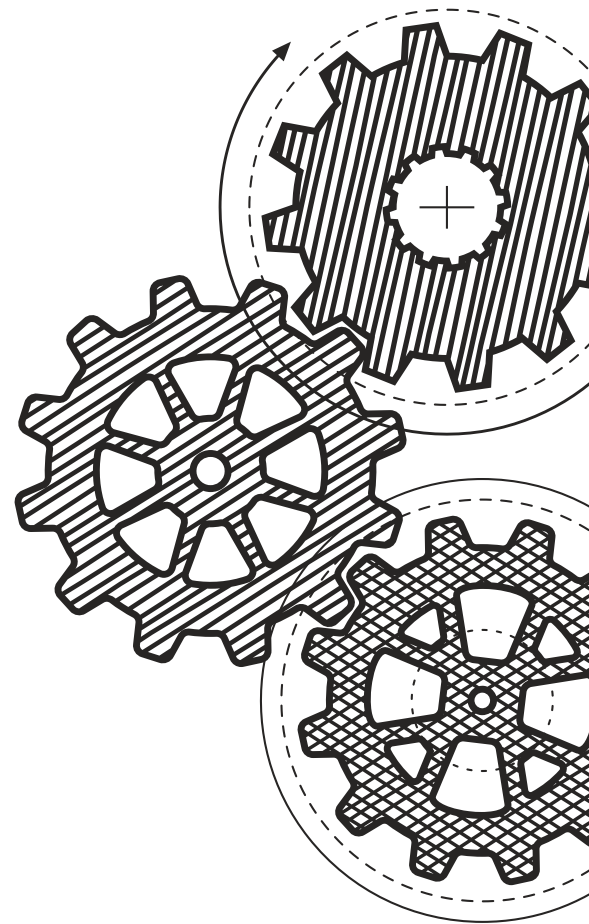

04

First sample production

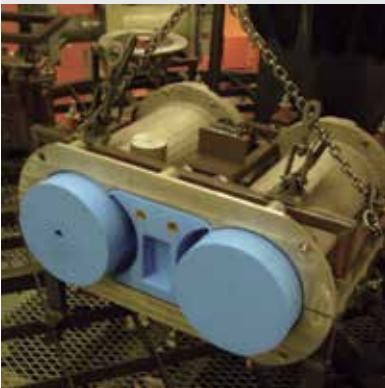

05

Serial production



06

Quality control



DEVELOPMENT PROCESS

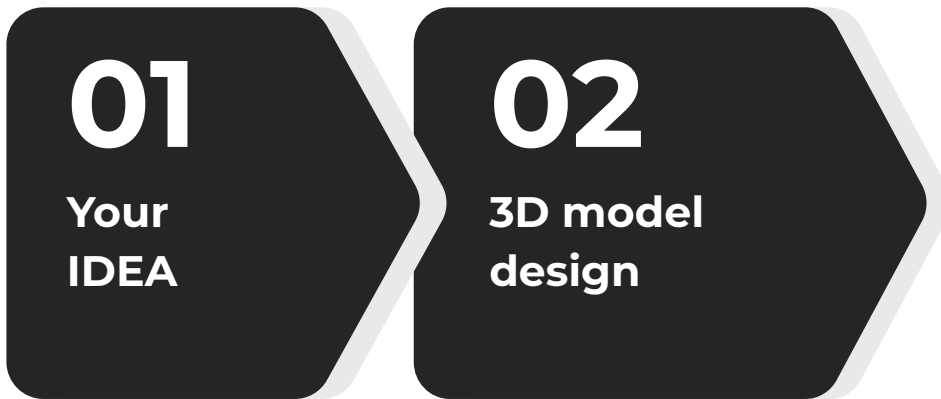

From your idea, sketch, 3D model, tool ... to the final product! Whole development process in 8 weeks!



ROTO's advantage is certainly its own tool development and production. So all the flow of information, together with the necessary and significant data is exchanged only between our customer and our development. Our staff, that is professionally qualified in technical areas, is always available to help you. If required, group meetings can be organised (it is possible to hold a videoconference), so that the desired goal is attained in the shortest time possible.

Licensed user of software:





ROTO's research and development center:

The goal of our research & development center is to enhance and fortify basic research. This is the place where we explore and develop innovative solutions across multiple fields.

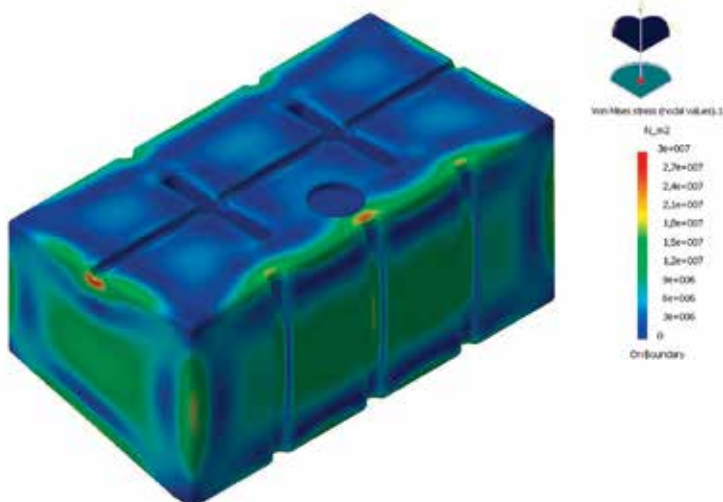

The scope of services of our development:

- 3D product design,
- FEA analyses,
- FMEA – risk assessment,
- tooling feasibility study,
- assembling drawing,
- prototyping.

TOOL WORKSHOP

03

**Mould
manufacturing
process**

04

**First sample
production**

We manufacture moulds suitable for rotomoulding with three different technologies:

- sheet metal moulds,
- cast aluminium moulds,
- moulds milled from block aluminium.

In our workshop we prepare mould surfaces according to the customers requirements (sand blasted or polished surface).

Product quality is highly dependent on the **mould quality**, therefore moulds are manufactured from quality materials and are periodically maintained in our workshop. Roto can also apply changes to existing moulds (e.g. new revision of product required, changing parts of the mould).

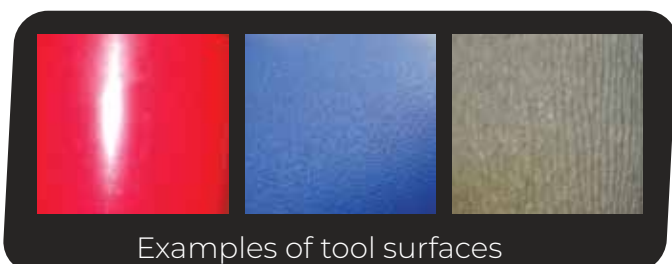

Examples of tool surfaces

According to the requests and specification of the product, different surface structures are possible, which are already determined during the development process, so appropriate tools are manufactured correspondingly.



3D sand printer

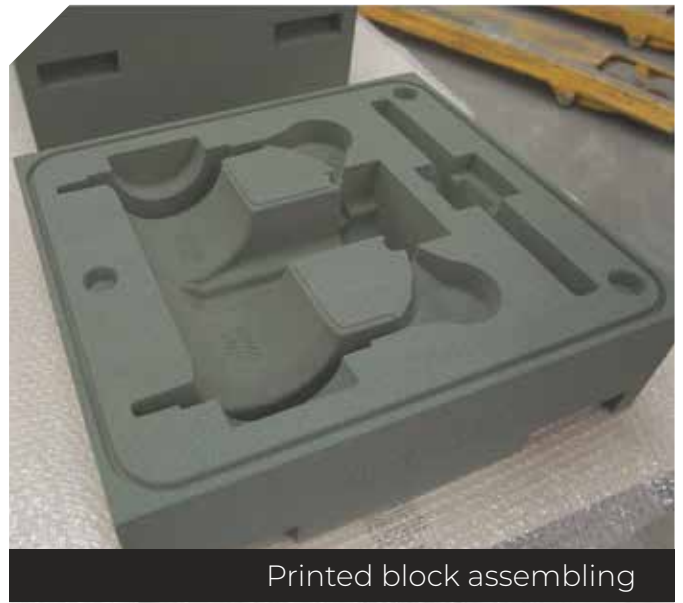

Printed block assembling



Aluminium casting



Tool assembly/finishing



5-axis block aluminium CNC machining

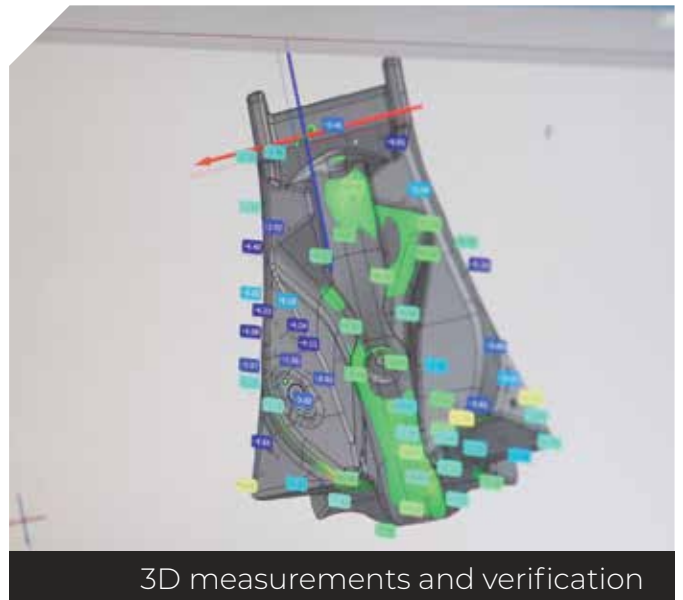

3D measurements and verification

PRODUCTION PROCESS

05

Serial production

Rotational moulding

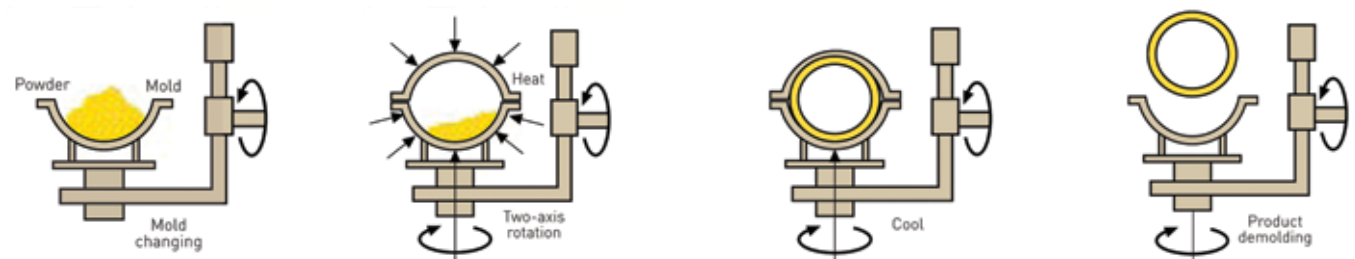

Rotational moulding involves a heated hollow mold which is filled with a charge or shot weight of material. It is then slowly rotated (usually biaxial), causing the melting material to disperse and stick to the walls of the mould. In order to maintain an even thickness throughout the part, the mould continues to rotate at all times during the heating phase to avoid sagging or deformation also during the cooling phase.

Each product that is manufactured within the rotomoulding process can be made from a wide range of colours or/and materials. End products can be UV resistant, resistant to most chemicals (depending on material type), multi layer and also in-mould features (threads, metal inserts, mould in graphics (MIG) ...) can be added to this product.

At ROTO Company, besides rotational moulding, our principal manufacturing process, we also carry out the following manufacturing procedures: **Thermoforming, Welding / Manufacturing products of PE and PP boards, Filament winding of composites.**

We use the following materials for various applications: **Polyethylene (LLDPE, XPE), Polypropylene (PP), Polyamide (PA6, PA12).** All these materials are 100 % recyclable (except for XPE).



We use various rotational moulding machinery:

- Carrousel rotational moulding machinery
- Clam Shell rotational moulding machinery
- Electric heated rotational moulding machinery
- Rock & Roll rotational moulding machinery



ROTO rotational moulding lab machine

Our laboratory rotational moulding machine used to perform tests and product development.



PRODUCT ASSEMBLING AND TESTING

06

Quality
control

Every product receives the following quality control:

- control inspection as per customer requirements,
- dimensional control and reporting of critical characteristics,
- leakage testing and reporting,
- wall thickness control,
- functionality control.

Customers want a product that can be easily installed into their machine, without spending extra assembly on his own (level gauges, connectors, heaters, reducing connectors, inserts, seals, brackets, covers).

Our assembling department is specialised in this kind of work. After installing the built-in parts, we carry out 100% quality control, which also includes pressure test of every volume product in a pool under the water, where the product is inflated with air at 0.3 bar for 5 minutes.

Described control procedure is digitally recorded and saved to MES (manufacturing execution system).



Quality control



Wall thickness control



Assembling process



5 axis CNC routing



Leaking testing process



Finishing and dimensional controlling



MARKET SEGMENTS

AGRICULTURAL MACHINERY



DIESEL TANK



AdBlue TANK



SILAGE TANK



Among the most important line of business of its abundant production program, ROTO also ranks components for agricultural mechanization. Sprayer tanks up to 8000 l, fuel tanks, AdBlue tanks, combine harvesters, silage tanks, cabin roofs, fenders for tractors, sprayers, air ducts, internal components for the cabin, hydraulic tanks, and expansion tanks.



MUD GUARD



Cabin roofs

LAMP HOLDER



Tanks for sprayers

MUD FLAP



Combine harvester components



CONSTRUCTION MACHINES

Today designers like to include plastic components like control panels, roofs, hoods and so on, to achieve a better look of construction machines. ROTO can manufacture components that look good, are functional, reliable and also resistant to heavy conditions in which these machines work daily.

But not just good look, construction machines also need reliable tanks under the hood. The challenge is that there is not much space left for the components. ROTO's ability is to produce tanks in complex shapes, light weight and with the possibility of welding at fractures.



Control panel components



Roofs for construction machinery

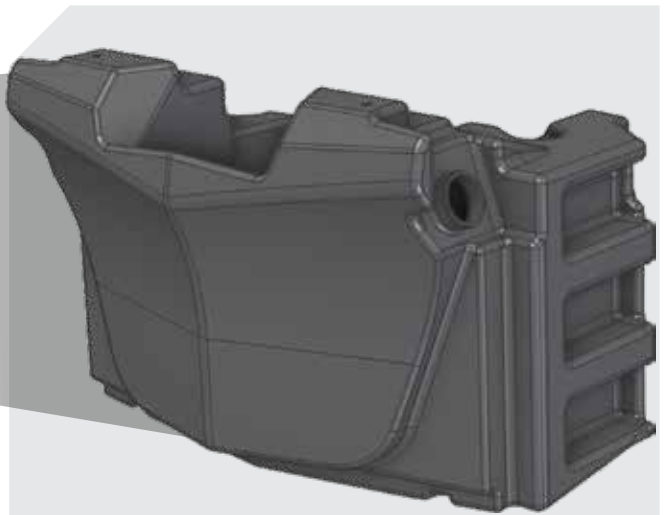

Fuel tanks for construction machinery

FIRE FIGHTING TECHNOLOGY & SNOW GROOMERS

They save lives on daily basis. So it is important to have a reliable water and foam tanks. Our many years of experience in the field of firefighting technology provide us the knowledge to make the best in the class. We can produce water tanks with capacity up to 10000 l, foam tanks, AdBlue tanks, fuel tanks, suction nozzles and other components according to the client's needs.



Foam tanks



Water tanks



Fuel tanks

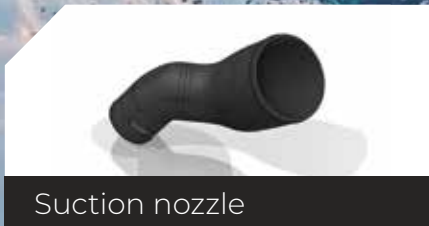

Suction nozzle



Fuel tanks for snowgroomers

TANKS & COMPONENTS FOR NAUTICS



Black water tanks



Gray water tanks



Fuel tanks

Every great boat or yacht deserves a reliable **FUEL & WATER** tank.

ROTO produces a fuel tanks for the marine industry (PE - Diesel and XPE - gasoline), fresh water tanks, grey water tanks, black water tanks, seats, exhaust connectors, set-top boxes for batteries, tool boxes and other items.

Fuel tanks are tested in-house in collaboration with certified institutes according to CE ISO 21487 and ABYC.

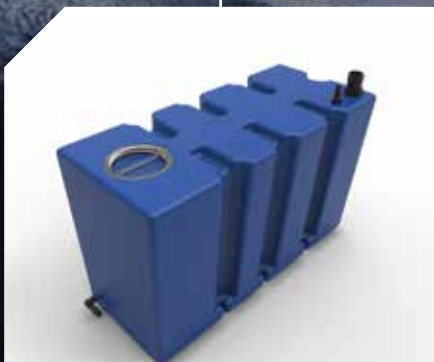

Fresh water tanks



Sump box



Other equipment

TANKS FOR CARAVANING



An indispensable product in the caravan branch are definitely tanks for fresh water and waste water systems for mobile homes and caravans. With the use or construction of these systems, it is possible to make full use of every cubic centimetre in a motorhome chassis.

Even in winter, the fluid in the reservoir is not a problem, while the tanks are available in 2 or 3 layer versions, in which we additionally mount heaters against freezing of liquids or we »dress« tanks in special insulated containers.



Fresh water tanks

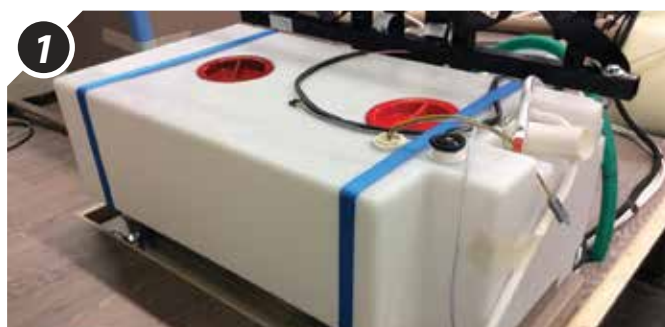

Fresh water tanks



Gray water tanks



Insulation for grey water tanks

AUTOMOTIVE & HI-TECH



Manufacturers of buses (urban, airport, travel), commercial vehicles, utility vehicles, special vehicles for forestry, special application for vehicles like mini vehicles, electric vehicles, are regularly seeking solutions from plastic. Fuel tanks, water tanks, coolant tanks, hoods,

masks are among the most common products produced with the ROTO long-time experience. Together with the certified institutes (TÜV, EXOVA), we also carry out all the necessary tests to obtain the relevant certificates.



Fuel tank for offroad motorcycles



Fuel tank for racing motorcycles



Aircraft fuel tanks



Housing for electric cars



Housing for electric cars



Aircraft anti icing liquid tanks

AIR SEPARATORS

For ROTO it is important to respect the environment. These free standing oil-water separators are state of the art of the technology. According to that matter, they need a reliable housing so they can deliver you unparalleled performance and reliability for minimal maintenance.



LOGISTICS - MANIPULATIONS



Internal transport, packaging, specialty pallets ... Exceptional durability, high load capacity, long life, impact resistance, UV stability ... In ROTO we create a comprehensive solution for your needs in terms of logistics and packaging.



Hygiene pallets



Cubi-container



Storage container tanks



Ultralight pallets



Pallets with telescopic pillars



Storage boxes



HEADQUARTERS:

ROTO d.o.o., Gorička 150, Černelavci

9000 Murska Sobota, Slovenia

Phone: 00386 (0)2 52-52-182

E-mail: industry@roto.si

www.roto.eu



roto



ROTO d.o.o.

Gorička 150, Černelavci
9000 Murska Sobota
Slovenia

Phone: +386 (0)2 52-52-182

E-mail: industry@roto.si

www.roto.eu